

OPERATORS' GUIDE

3000 SERIES



PDC-3000 SHOWN
PCU-3000 INCLUDES COUPLERS

PDC-3000/PCU-3000

DOUBLE ACTING
HYDRAULIC CUTTER

REL-3000SA

SINGLE ACTING
HYDRAULIC CUTTER

The 3000 Series guillotine-type cutter will make a straight, clean cut every time. These cutters can be used for cutting a wide range of electrical conductors up to 3.35 inch.



WARNING



All information found in this guide must be read and understood before use or testing of this tool.

Failure to read and understand these warnings and safe handling instructions could result in severe personal injury and or death.



RELIABLE EQUIPMENT & SERVICE CO., INC.

DISTRIBUTED BY

REGISTRATION

UPON RECEIPT OF THIS TOOL, COMPLETE THE REGISTRATION BELOW.

COMPANY _____

ADDRESS _____

PHONE _____ FAX _____

SERIAL NUMBER _____

DATE OF PURCHASE _____

DEALER NAME _____

TABLE OF CONTENTS

DISTRIBUTOR INFORMATION	2
TABLE OF CONTENTS.....	3
REGISTRATION	3
TOOL SPECIFICATIONS	4-5
SAFETY INFORMATION AND WARNINGS	6-9
OPERATING INSTRUCTIONS	10
DAILY MAINTENANCE	11
LABELS	11
PDC-3000 PARTS DIAGRAM	12
PDC-3000 - PARTS LIST.....	13
REL-3000SA PARTS DIAGRAM	14
REL-3000SA - PARTS LIST	15
MAINTENANCE RECORDS	16
CONTACT INFORMATION	16



THIS SYMBOL INDICATES ITEMS OF EXTREME IMPORTANCE.

Safety of user and others may be in jeopardy if these instructions are not read and understood.

NOTICE

The information found in this manual is subject to change without notice. Contact **RELIABLE EQUIPMENT** for the most recent version of this manual.

RELIABLE EQUIPMENT & SERVICE CO., INC.
92 Steamwhistle Drive • Ivyland, PA 18974 • USA
Phone: 215-357-3500 • Fax: 215-357-9193

MODEL: ;-3000
MAX. PRESSURE: 10,000 PSI
SERIAL NO.: _____
YEAR: _____





RELIABLE EQUIPMENT & SERVICE CO., INC.

Weight: 21 lb.
Length: 17.5 in.
Width: 7.5 in.

Head opens for cable insertion along the line

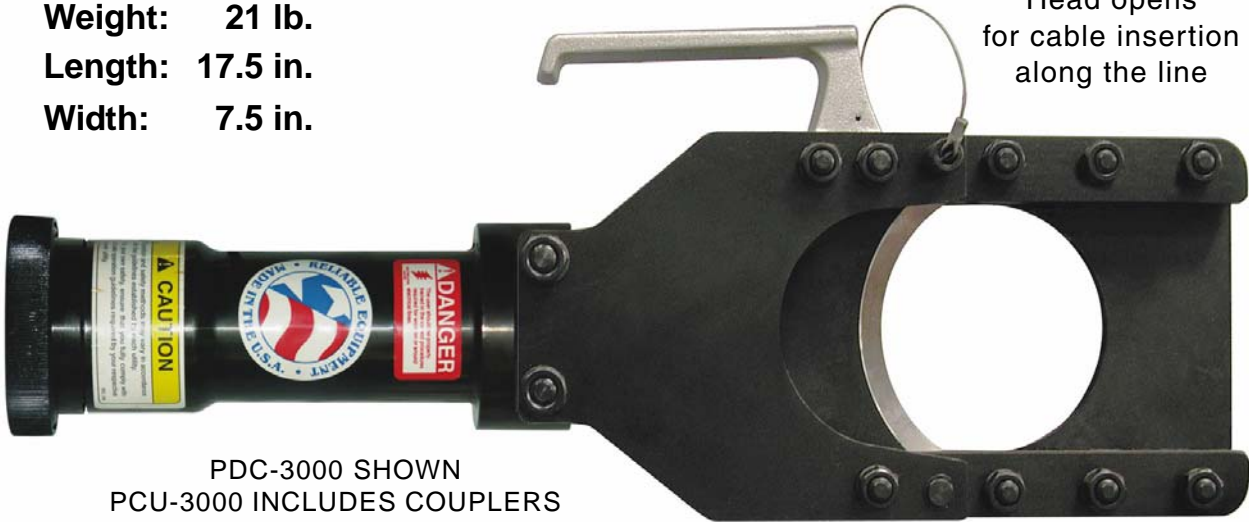

PDC-3000 SHOWN
 PCU-3000 INCLUDES COUPLERS

PDC-3000

DOUBLE ACTING HYDRAULIC CUTTING TOOL



The 3000 Series guillotine-type cutter will make a straight, clean cut every time. These cutters can be used for cutting a wide range of electrical conductors. Head opens easily for inserting cable at any location along line. Double-acting operation eliminates hang-up problems, and offers full control of cutting action. The 360° rotating head eliminates hose twisting and increases operator speed and comfort.

FEATURES

- Lightweight, compact guillotine design provides a clean, positive cut.
- Cutting head is easily opened for cable insertion at any location in line.
- 360° head eliminates hose twisting.
- Built-in Auxiliary Handle

3000 SERIES - MAXIMUM CONDUCTOR CAPACITY

System	Double-Acting
Capacity (Jaw Opening)	3.35 inch.
Force @ 10,000 psi (690 bar)	28,048 lb.
Return @ 5,000 psi (345 bar)	10,445 lb.
Max Operating Pressure	10,000 psi (690 bar)
Max Return Pressure	5,000 psi (345 bar)
Couplers	Direct Connect

Soft Copper Jacket	3"
Aluminum Jacket	3"
Lead Sheathed Cable	3.35"
Communication Cable	3.35"



RELIABLE EQUIPMENT & SERVICE CO., INC.

Weight: 21 lb.
Length: 17.5 in.
Width: 7.5 in.

Head opens for cable insertion along the line



REL-3000SA

SINGLE ACTING HYDRAULIC CUTTING TOOL



The **REL-3000SA** guillotine-type cutter will make a straight, clean cut every time. These cutters can be used for cutting a wide range of electrical conductors. Head opens easily for inserting cable at any location along line. This Single-acting cutter will compliment existing single acting systems. The 360° rotating head eliminates hose twisting and increases operator speed and comfort.

FEATURES

- Lightweight, compact guillotine design provides a clean, positive cut.
- Cutting head is easily opened for cable insertion at any location in line.
- 360° head eliminates hose twisting.
- Built-in Auxiliary Handle

System	Single-Acting
Capacity (Jaw Opening)	3.35 inch.
Force @ 10,000 psi (690 bar)	28,048 lb.
Return @ 5,000 psi (345 bar)	10,445 lb.
Max Operating Pressure	10,000 psi (690 bar)
Max Return Pressure	5,000 psi (345 bar)
Couplers	Direct Connect

3000 SERIES - MAXIMUM CONDUCTOR CAPACITY

Soft Copper Jacket	3"
Aluminum Jacket	3"
Lead Sheathed Cable	3.35"
Communication Cable	3.35"



WARNING

BEFORE USING THIS TOOL, READ THE WARNINGS and the recommended practices described in this manual. Failure by the operator to read and fully understand these warnings will leave this person unqualified to use and operate this tool. Property damage, severe personal injury, and/or death could result by not following these warnings.

These warnings will appear in appropriate locations when they are pertinent to the particular subject being shown. Read each one carefully and follow them strictly.



Eye Protection

WARNING

Always wear eye protection to avoid injury from flying debris or hydraulic oil leaks. Failure to do so can result in serious personal injury.



Dust Mask

WARNING

Always wear a dust mask. Failure to observe this warning may result in serious health issues and/or breathing difficulty.



Hard Hat

WARNING

Always wear a hard hat to avoid injury from falling debris. Failure to do so can result in serious personal injury.



Foot Protection

WARNING

Always wear foot protection. Failure to do so can result in serious personal injury.



Hearing Protection

WARNING

Always wear hearing protection, to avoid hearing loss due to long term exposure to high noise levels.



Protective Gloves

WARNING

Always wear protective gloves. Failure to do so can result in serious personal injury.



WARNING

SAFE OPERATION & CARE

USE THIS TOOL FOR ITS INTENDED PURPOSE ONLY
Any other use can result in injury or property damage.

INSPECT TOOL BEFORE USE. Replace any worn, damaged or missing parts. A damaged or improperly assembled tool may malfunction, injuring operator and/or nearby personnel.

INSPECT HYDRAULIC HOSES AND COUPLINGS before each use. Repair or replace if any cracking, leakage, wear or damage is found. Worn or damaged hoses may fail resulting in personal injury or property damage.

CLEAR WORK AREA of all bystanders and unnecessary personnel before operating this tool.

KEEP ALL PARTS OF THE BODY AWAY FROM MOVING PARTS.

Failure to observe this warning could result in serious injury.



WARNING

HYDRAULIC POWER SUPPLY

DO NOT attempt to make any changes to any of the component parts or accessories when connected to the power source.

DO NOT adjust, inspect, or clean tool while the tool is connected to the power source. The tool could accidentally start up and cause serious injury.

DO NOT lock the tool in the On Position. In an emergency, serious damage or injury could occur during the time required to stop the tool.



WARNING

OIL INJECTION INJURY

Hydraulic oil or fluid under the skin is a serious injury. Oil under pressure can penetrate the skin and may cause dismemberment or loss of life. Seek medical assistance immediately if such an injury should occur.

Always wear safety gloves, eye protection and all required safety equipment when operating or handling this tool.

DO NOT use fingers or hands to attempt to locate a leak.

DO NOT handle hoses or couplers while system is pressurized.

NEVER open or service the system before depressurizing.



WARNING

HOSES AND FITTINGS

There exists the potential for shock in using anything other than certified nonconductive hoses and hydraulic oil with dielectric properties, when using system components near energized electrical lines. Failure to recognize these conditions could cause electrocution.

Hoses and fittings used with this tool must comply with S.A.E. J1273 which covers recommended practice for selection, installation, and maintenance of hose and hose assemblies. The **correct hoses and fittings are available from your supplier.**

WARNING: Failure to comply with these warnings could result in severe bodily injury.



WARNING

UNIT/HOSE CONNECTIONS

ALWAYS DISCONNECT pump/power source and move toggle switch to **OFF** before connecting or disconnecting any components.

ALWAYS DEPRESSURIZE hydraulic system, before slowly disconnecting this unit or any of the systems components.

ALWAYS TIGHTEN couplings completely. Loose or improperly tightened couplings will not allow fluid to pass through the hose creating a blockage in the supply or return line.

ALWAYS INSPECT HOSES AND CONNECTORS before connection to tool. Replace or repair if any leakage is evident. Leakage is a sign of deterioration in component parts. Worn or leaking parts must be repaired or replaced, or tool damage or severe injury could result.



CAUTION

HOSE INSTALLATION

ALWAYS ENSURE CONNECTORS ARE CLEAN

DOUBLE ACTING - Care must be taken to assure the correct connection of the hoses to the pressure and return (tank) ports.

Connect the return hose to the return (tank) port on the power source, then to the return port on the tool.

Connect the pressure hose to the pressure port on the tool, then to the "P" pressure port on the power source.

Operation with hydraulic flow reversed can cause malfunction.

SINGLE ACTING - Connect the pressure hose to the pressure port on the tool, then to the "P" pressure port on the power source. Failure to fully comply can result in severe injury or death.



WARNING

Operation/Safety methods may vary in accordance with the working guidelines established by each utility or contractor.

For your own safety, ensure that you fully comply with all safe operation guidelines required by your employer.



WARNING

ELECTRICAL SHOCK HAZARD

Always wear and use the necessary clothing, equipment and safety practices to protect against electrical shock. Failure to follow these rules can result in serious personal injury or death.



GENERAL SAFETY



USE ALL APPROPRIATE AND APPLICABLE PERSONAL SAFETY EQUIPMENT as required by the operating company.

ALWAYS INSPECT TOOL for wear or deterioration every day. Replace all parts that show signs of wear or damage.

KEEP ALL PARTS OF THE BODY AWAY from moving parts of the tool.

KEEP HANDS OUT FROM BETWEEN FIXED AND MOVING BLADES AT TOOL HEAD.

HANDS SHOULD BE OUTSIDE DANGER ZONE PRIOR TO ACTIVATING BLADE.

MAKE SURE there is no person in close proximity to you or the tool who could be injured by any operation being performed, tool malfunction or flying debris.

DO NOT OVEREXTEND your position by overreaching or unbalancing the footing necessary to maintain physical control of your body.

ALWAYS MAINTAIN a firm grip on the tool to avoid loss of control during an operation, causing property damage, serious injury or death.

USE THIS TOOL FOR THE MANUFACTURERS' INTENDED PURPOSE ONLY.

OBSERVE CLOSELY ALL SAFETY RULES FOR A PARTICULAR JOB CLASS

**FAILURE TO HEED THESE WARNINGS COULD RESULT IN
PROPERTY DAMAGE, SERIOUS PERSONAL INJURY OR DEATH.**

OPERATION



WARNING

Do not cut live conductors.

Hardened metals may fly when severed.

Take necessary precautions. wear safety glasses.

Keep all body parts away from cutting blades and moving parts.

Failure to follow these rules can result in serious personal injury or death.

Read entire manual prior to using this tool. (Refer to all safety recommendations and warnings)

Observe all safety precautions and procedures required by the operating company.

(Refer to GENERAL SAFETY on previous page)

Before cutting, ensure that material being cut is within the capacity listed for this tool.

Tool must be used in conjunction with a hydraulic system rated at, and adjusted to, 10,000 psi. Any system not operating at 10,000 psi may cause damage to the tool and result in serious injury to the operator.

Connect the tool head to the control valve or hose set. (Refer to warnings on page 6 & 7)

Open cutter by removing locking pin.

Insert material between cutter head and blade.

Close and secure cutter head using locking pin. Failure to secure head may result in severe tool damage and/or personal injury.

The material to be cut MUST be at a 90° angle to the blade. This will ensure a proper cut with minimal distortion. Severe blade damage may occur if material is cut at any other angle.

Operate pump or valve to slowly advance blade. If a hold feature is available, check for proper alignment (90° angle) of blade and material being cut.

Continue until cut is complete.

Double Acting: Use valve or pump to retract blade.

Single Acting: Blade will return by internal spring.



CAUTION

The information in this manual is intended to guide the user in the use and application of this tool. It is not intended as a substitute for proper training and experience in safe work practices for this type of equipment.

Consult your supervisor or safety personnel if you have any questions regarding the safe operation of this tool.

DAILY MAINTENANCE

The life, reliability, and safety of the tool is dependent on proper maintenance. **Clean** all surfaces including head, blade, couplers (if coupled), threads, and handles. **Inspect** for wear and damage. Worn or damaged parts may malfunction during operation. **All parts must be replaced with new parts if signs of wear or damage are evident.** Keep Label Set clean and legible. Replace decals when necessary. Part #RL23400



IMPORTANT: The greatest cause of hydraulic pump failure is dirt. Prevent the introduction of foreign matter into the unit via hydraulic fluid, dirty connections or accumulation of sediment.

Part # RL3000

NOTE: Keep Label Set clean and legible. Replace decals when necessary.



WARNING

BEFORE USING THIS PRODUCT READ THE SAFETY WARNINGS and recommended practices described in the manual. Failure by the operator to read and fully understand the warnings will leave this person unqualified to use and operate the tool.

Failure to observe all warnings and instructions could result in property damage, severe personal injury, and/or death.

RELIABLE EQUIPMENT & SERVICE CO., INC.
92 Steamwhistle Drive • Ivyland, PA 18974 • USA
Phone: 215-357-3500 • Fax: 215-357-9193

MODEL: :-3000

MAX. PRESSURE: 10,000 PSI

SERIAL NO.: _____

YEAR: _____



CAUTION

Operation and safety methods may vary in accordance with the guidelines established by each utility. For your safety, ensure that you fully comply with all safe operation guidelines established by your respective power utility. REL-SM

DANGER



The user should be properly trained in the correct procedures required for work on or around electrical lines.



**DANGER
BLADE
CLOSES**

Complete disassembly is not recommended. Return the unit to an authorized dealer for total disassembly and/or repair.

All maintenance or disassembly should take place on a flat, clean work surface covered with towels or wipers so as to have a clean space for the disassembled parts.

Inspect each part during disassembly for wear, scratches, and cuts. Discard the worn or damaged parts and replace with new factory authorized parts.

O-rings are sensitive to sharp edges. Inspect closely for cuts or damage. A small cut will cause a leak. When assembling or disassembling O-rings, use hydraulic fluid as a lubricant to help disassembly or installation.

PDC-3000 PARTS DRAWING

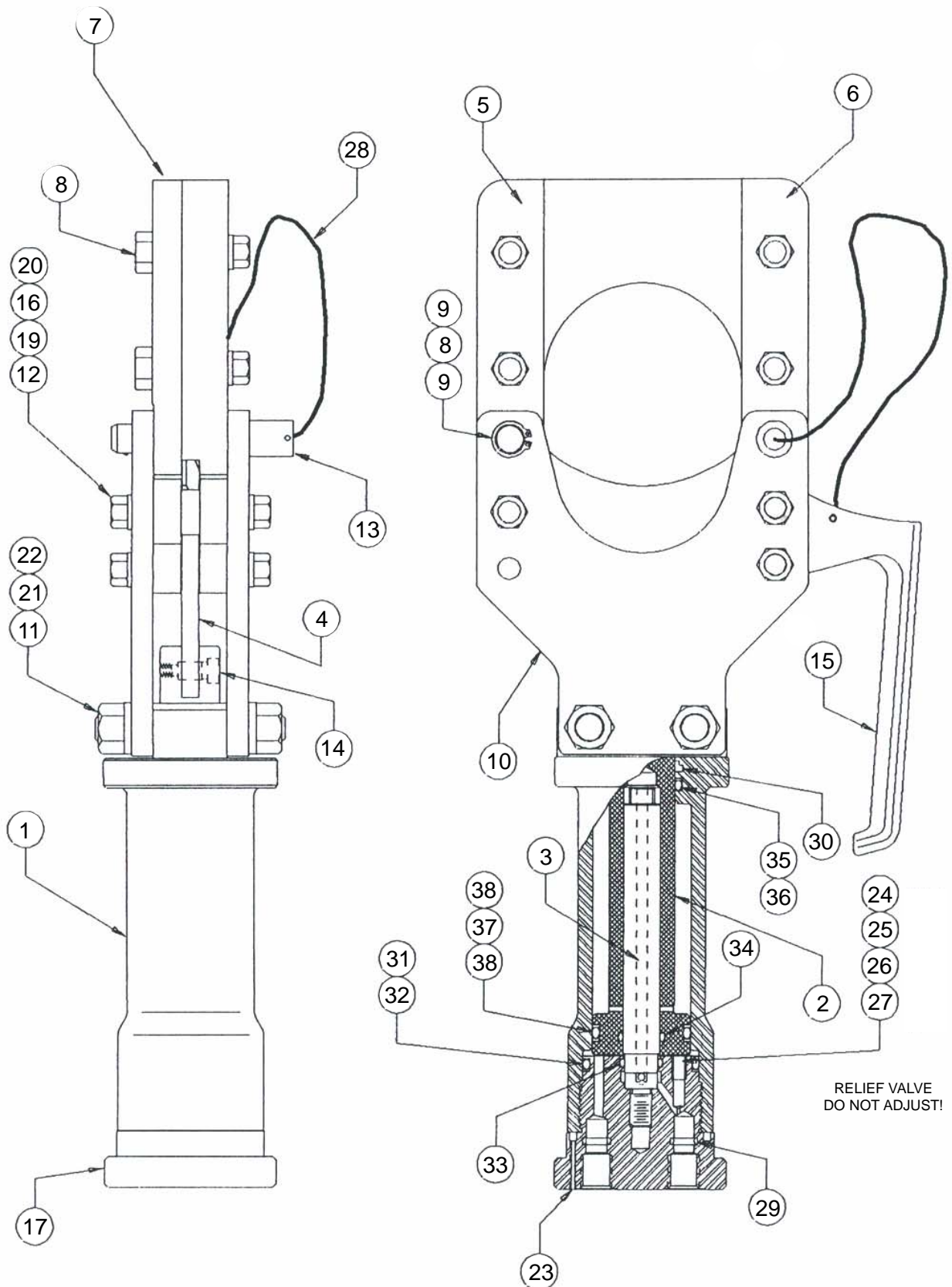

PDC-3000 PARTS LIST

#	PART	QTY	PART #
1	CYLINDER	1	R30001
2	RAM	1	R30002
3	INNER PISTON	1	R30003
4	MOVING BLADE	1	R30004
5	RAIL, HINGED SIDE	1	R30005
6	RAIL, HANDLE SIDE	1	R30006
7	HINGED CUTTER	1	R30007
8	CONNECTING PIN	1	R23003
9	PIVOT PIN	2	R23014
10	RETAINING RING (FOR 23003)	2	R30010
11	SIDE PLATE	2	R23006
12	LARGE STUD	3	R23005
13	DETENT PIN	1	R23010
14	BOLT, RETAINING (HOLDS MOVING BLADE)	1	R23008
15	HANDLE	1	R23015
16	GUIDE ROLL	2	R23007
17	END BLOCK	1	R23013
18	BOLT, FOR PIVOT PLATE	4	R26024
19	SLIT LOCK WASHER	10	R23020
20	GRADE 8 HEX NUT	10	R23021
21	SLPIT LOCK WASHER	4	R23022
22	GRADE 8 HEX NUT	4	R23023
23	SET SCREW. SOCKET	2	R15006
24	ADJUSTING SCREW	1	12124
25	SPRING	1	12126
26	BALL RETAINER	1	12125
27	CHECK BALL	1	12129
28	LANYERD	1	R26061
29	O-RING, FOR END CAP	2 *	R15011
30	WIPER	1 *	R23024
31	O-RING (GOES ON END BLOCK)	1 *	R15014
32	BACK-UP RING	1 *	R15015
33	O-RING (GOES IN END BLOCK)	1 *	R23028
34	O-RING (GOES IN RAM)	1 *	R23034
35	O-RING (GOES IN CYLINDER)	1 *	R23028
36	BACK-UP RING	1 *	R23027
37	O-RING (GOES ON RAM)	1 *	R30037
38	BACK-UP RING	2 *	R30038
39	SEAL KIT (* DENOTES ITEMS INCLUDED IN SEAL KIT)	1	R30039
PCU-3000 (Also includes couplers below)			
	HIGH PRESSURE COUPLER - MALE	1	130868
	HIGH PRESSURE COUPLER - FEMALE	1	130878

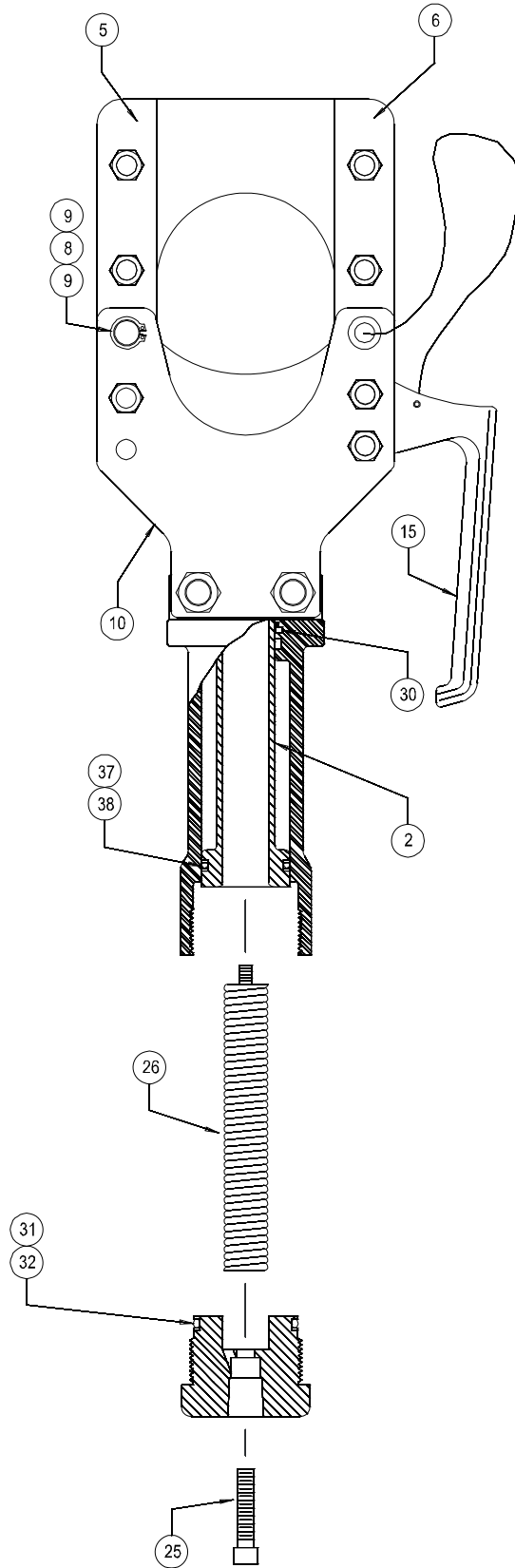
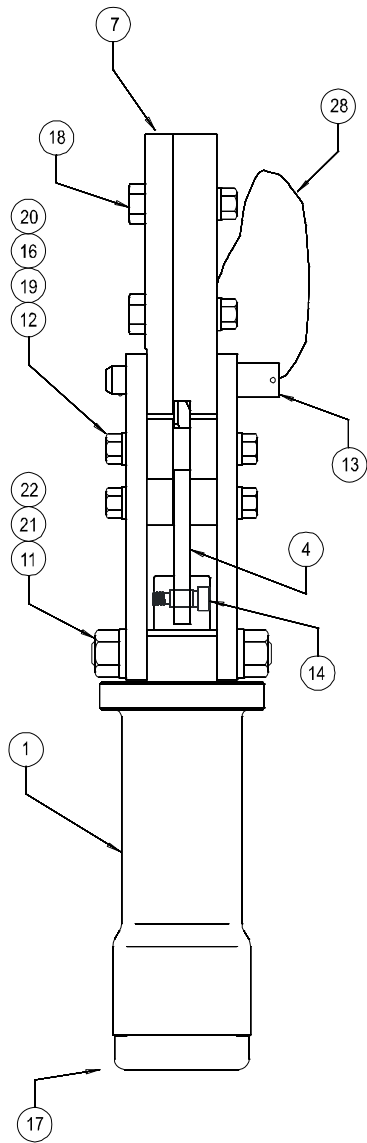

REL-3000SA
PARTS DRAWING

PDC-3000 PARTS LIST

#	PART	QTY	PART #
1	30001	1	CYLINDER
2	30052	1	RAM
4	30004	1	MOVING BLADE
5	30005	1	RAIL, HINGED SIDE
6	30006	1	RAIL, HANDLE SIDE
7	30007	1	HINGED CUTTER
8	23003	1	PIVOT PIN
9	23014	2	RETAINING RING
10	30010	2	SIDE PLATE
11	23006	2	LARGE STUD
12	23005	3	SMALL STUD
13	23010	1	DETENT PIN
14	23008	1	BOLT, RETAINING
15	23015	1	HANDLE
16	23007	1	GUIDE ROLL
17	30053	1	END BLOCK
18	26024	4	BOLT, PIVOT PLATE
19	23020	10	SPLIT LOCK WASHER, SMALL
20	23021	10	HEX NUT, SMALL
21	23022	4	SPLIT LOCK WASHER, LARGE
22	23023	4	HEX NUT, LARGE
25	30054	1	SCREW, RETURN SPRING
26	30056	1	RETURN SPRING ASSEMBLY
28	26061	1	LANYARD
30	23024	1	WIPER
31	15014	1	O RING, END BLOCK
32	15015	1	BACKUP RING, END BLOCK
37	30037	1	O RING, RAM
38	30038	2	BACKUP RING, RAM
	30039	1	SEAL KIT

* ITEMS INCLUDED IN SEAL KIT

