



Tooling solutions for the power utility industry.

RIDGID STRAIGHT PIPE WRENCH

Sturdy, cast-iron housing and I-beam handle with full floating hook jaw, nonstick adjustment nut and replaceable hook and heel jaws.

Size	8"	10"	12"	14"	18"	24"	36"	48"
Pipe	1"	1-1/2"	2"	2"	2-1/2"	3"	5"	6"
Part	31005	31010	31015	31020	31025	31030	31035	31040



31005

ALUMINUM HANDLE PIPE WRENCH

Nearly 40% lighter than comparable cast-iron models of the same size. Jaws and all other parts identical to H/D wrenches. Also available with special hook and heel jaws for plastic coated pipe.

Size	10"	14"	18"	24"	36"	48"
Pipe	1-1/2"	2"	2-1/2"	3"	5"	6"
Part	31090	31095	31100	31105	31110	31115



31090

LINEMAN'S WRENCHES - Standard Type

Forged from special bar steel and heat treated. Each end has two size openings. Hole is provided at larger end for turning-in standard pole steps. Wrench is particularly suited for use on three-bolt guy clamps with limited clearance. 13" Long. Available for 5/8" or 3/4" hardware.

3146 - For 5/8" hardware. Lg End 1-3/32" & 29/32". Sm End 13/16" & 5/8". Dark blue painted finish.

3146A - For 3/4" hardware. Lg End 1-1/16" & 1-5/16". Sm End has 5/8" & 7/8". Painted dark blue with small end painted white.

3146B - Bell System Type for NEMA hardware. Lg End 1-1/16" & 1-3/16". Sm End 11/16" & 7/8". White painted finish.



3146A

3239 - ADJUSTABLE-HEAD CONSTRUCTION WRENCH

Versatile wrench fits all nuts and bolts to 1-1/2". Eliminates the need for carrying several fixed-size wrenches. Drop-forged from select alloy steel with continuous-taper handle. Black finish. **Maximum Size Capacity: 1-1/2", Length: 15".**



3239

5460 - ERECTION WRENCH HOLDER

Wrench holder has slots for two erection wrenches. Slotted for sliding on 2" wide belt. Size: 6" x 8".

5459 - TUNNEL LOOP WRENCH HOLDER

Permits use on wider belts or to slide over D-rings, buckles, and accessories. **NOT SHOWN.**



5460

TO ORDER CALL: 800-966-3530 OR FAX: 215-357-9193



Tooling solutions for the power utility industry.



COMBINATION WRENCHES

The gleaming chrome finish is attractive, extra-smooth, and corrosion resistant. Open and box ends are the same size on each end. **Open ends** are offset at standard 15° angle for working in confined areas. **Box ends** have a 15° angle offset to provide clearance over obstructions.

Individual Combination Wrenches

Part	Size	Length
68410	1/4"	3-15/16"
68411	5/16"	4-3/4"
68412	3/8"	5-1/4"
68413	7/16"	5-13/16"
68414	1/2"	6-1/16"
68415	9/16"	7-3/16"
68416	5/8"	8"
68417	11/16"	8-25/32"
68418	3/4"	9-5/8"

Part	Size	Length
68419	13/16"	10-9/16"
68420	7/8"	11-1/2"
68421	15/16"	12-1/2"
68422	1"	13-1/2"
68423	1-1/16"	14-5/8"
68424	1-1/8"	15-9/16"
68425	1-1/4"	16-7/8"
68402	9pc Set (1/4"- 3/4" W/ Pouch)	



68202

RATCHETING BOX WRENCHES

For use in confined spaces and on long studs. Laminated construction. Ratchet is reversed by turning wrench over. Chrome-plated finish. Single-hex and double-hex types available. Different size openings at each end.

Double Hex

Part	Size	Length
68200	1/4" x 5/16"	4-1/4"
68201	3/8" x 7/16"	5-1/2"
68202	1/2" x 9/16"	6-1/2"
68203	11/16" x 11/16"	8"
68204	5/8" x 3/4"	8"

Single Hex

Part	Size	Length
68205	11/16" x 3/4"	9-1/4"
68206	13/16" x 7/8"	9-1/4"
68222	7 pc. set (Above w/ pouch)	



507-8

ADJUSTABLE WRENCHES

Jaws open 3/16" wider than standard wrenches, length for length. Ideal for use in confined spaces. Chrome plated.

Part	Length	Capacity
507-6	6"	15/16"
507-8	8"	1-1/8"
507-10	10"	1-5/16"
507-12	12"	1-1/2"

TO ORDER CALL: 800-966-3530 OR FAX: 215-357-9193

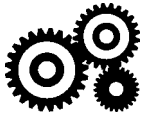

Tooling solutions for the power utility industry.

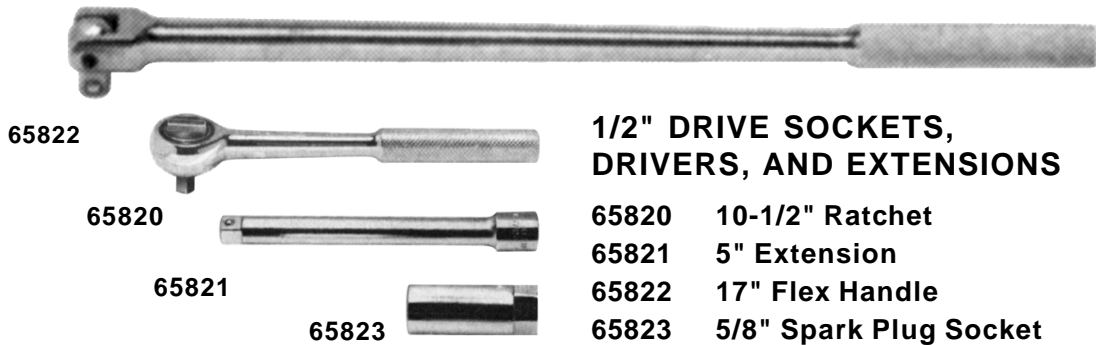

1/2" DRIVE SOCKETS, DRIVERS, AND EXTENSIONS

65822



65820 10-1/2" Ratchet

65820



65821 5" Extension

65821



65822 17" Flex Handle

65823

65823 5/8" Spark Plug Socket

STANDARD 12-POINT SOCKETS, 1/2-INCH DRIVE

Size	7/16	1/2	9/16	5/8	11/16	3/4	13/16	7/8	15/16	1	1-1/16	1-1/8	1-1/4
Part	65800	65801	65802	65803	65804	65805	65806	65807	65808	65809	65810	65811	65812

DEEP 12-POINT SOCKETS, 1/2-INCH DRIVE

Size	1/2	9/16	5/8	11/16	3/4	13/16	7/8	15/16
Part	65825	65826	65827	65828	65829	65830	65831	65832

12-POINT
1/2" DRIVE
SOCKET

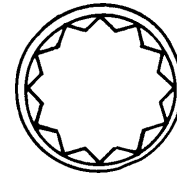

REL-151T - LINEMAN'S WRENCH

Reliable Equipment's Ratcheting Triple Square Wrench was designed for the three most common fasteners on utility poles, lag bolts, "C" clamps, and suspension bolts with speed and safety.

Features include: Bolt thru socket which allows the bolt to pass entirely through so nuts can be tightened down to any threaded length; reversible ratchet mechanism; H/D, lightweight construction; 3-in-1 combination socket (3/4", 1", 1-1/8") with 12" handle and comfortable hand grip. Eliminates the need for multiple wrenches and sockets. (2.25 lbs.)



REL-PSW PENTA SOCKET WRENCH

The Reliable ReL-PSW is a ratcheting socket wrench designed to tighten or loosen special 5-point penta head nuts and bolts common to most pad mounted transformers. Wt. 1.25 lbs.

FEATURES INCLUDE:

- Easy ratcheting action for tight spaces
- Quick change forward & reverse lever
- Supplied standard with Penta Socket on one side, 3/4" 6-point socket on the other (other configurations available)
- Cushion grip



TO ORDER CALL: 800-966-3530 OR FAX: 215-357-9193



Tooling solutions for the power utility industry.



ERECTION WRENCHES

Drop-forged from select alloy steel to withstand high-leverage and heavy loads. Extra-deep offset handle provides additional hand-clearance. Continuous taper of handle makes lining up bolt holes easy, allows use on a range of bolt hole sizes. Extra-large hub area allows use on larger diameter holes. Number, bolt size, and nominal opening size are stamped on wrench for easy identification.

Part	Nut Type	Bolt	Opening	Length
3210	U.S. Heavy	1/2"	7/8"	12-1/2"
3211	U.S. Heavy	5/8"	1-1/16"	14-3/4"
3212	U.S. Heavy	3/4"	1-1/4"	16-1/2"
3213	U.S. Heavy	7/8"	1-7/16"	17-1/4"
3214	U.S. Heavy	1"	1-5/8"	17-11/16"
3220	U.S. Regular	1/2"	13/16"	14-1/2"
3221	U.S. Regular	5/8"	1"	14-3/4"
3222	U.S. Regular	3/4"	1-1/8"	16-1/2"
3223	U.S. Regular	7/8"	1-5/16"	17-1/4"
3224	U.S. Regular	1"	1-1/2"	17-11/16"
3231	Utility	5/8"	15/16"	14-3/4"
3232	Utility	3/4"	1-1/16"	16-1/2"



3238 - 1/2" SQUARE DRIVE RATCHETING CONSTRUCTION WRENCH

1/2" square-drive, hex socket, reversible ratchet eliminates the need for carrying several fixed-size wrenches. Drop-forged from select alloy steel with continuous taper handle for aligning bolt holes. Industrial black finish. 15" Overall Length.



3255 - BROAD-HEAD BULL PIN

This improved bull pin provides a larger striking surface. Head design reduces chance of pin slipping from the hand when aligning holes. Squared-off shoulders have been forged to provide a surface for applying a wrench to loosen wedged bull pins. Long, even taper reduces binding and hang-up. Broad-head bull pins resist "mushrooming", permitting longer use than conventional designs. 1-1/4" Top Dia., 5/16" Point Dia., 13" Length.

NOTE: OSHA specifically states, "impact tools such as drift pins, wedges, and chisels shall be kept free of mushroomed heads."

BARREL-TYPE DRIFT PINS

Drop-forged steel, will properly end-pein in use.



Part	Max. Dia.	Point Dia.	O.A.L.
3260	11/16"	5/16"	7 1/2"
3261	13/16"	7/16"	8"
3262	15/16"	1/2"	8"
3263	1-1/16"	9/16"	8"

TO ORDER CALL: 800-966-3530 OR FAX: 215-357-9193