

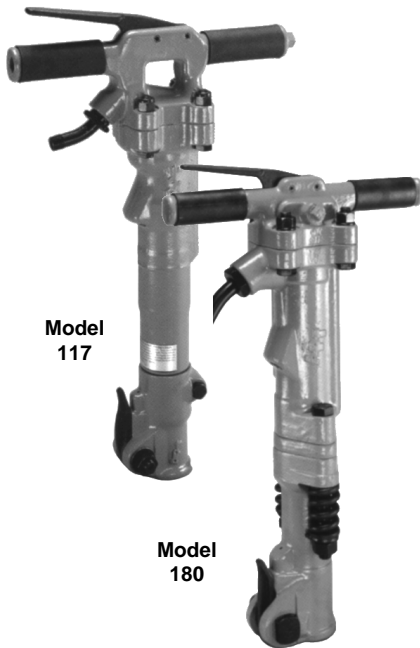

Tooling solutions for the power utility industry.



Model
117

Model
180

PAVING BREAKERS

- Automatic valves
- Built-in automatic oiler
- Latch type retainer
- Swivel hose connection
- Four-bolt backhead
- Replaceable chuck bushing (Except 140/140A)
- Drop forged alloy steel handle and rubber grips

Model 117 - 30 lb. Class **Model 160** - 60 lb. Class
Model 140 - 40 lb. Class **Model 180** - 90 lb. Class

AIRGO-LINE[®] - 40 lb., 60 lb., 90 lb. Classes

- Vibration dampening ergonomic handle designed to absorb the shock to the operator.
- Handle is interchangeable with APT standard model
- Delivers the same hitting power as the standard breaker with less fatigue to the operator.
- Replaceable vibration isolator.

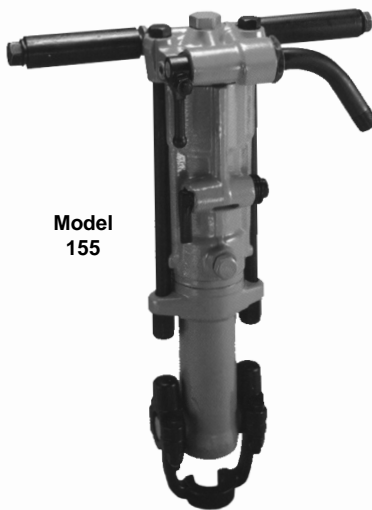

Model
155

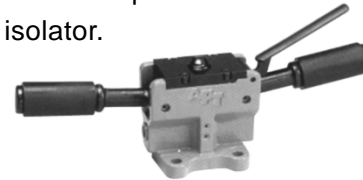

MODEL 155 - 60 LB. CLASS

- 3 drilling speeds
- Replaceable piston stem bearing
- Built-in automatic oiler
- Available wet or dry
- Counter clockwise rotation
- Rubber handle grips

Model	Chuck Size	Bore	Stroke	B.P.M.	CFM @ 90 PSI	Weight	Length	Air Inlet NPT
-------	------------	------	--------	--------	--------------	--------	--------	---------------

PAVING BREAKERS

117	7/8 x 3-1/4 · 1 x 4-1/4	1-3/4	3-3/8	2400	34-38	33 lbs.	21-3/4	3/8 male
140	1 x 4-1/4	1-7/8	4-1/4	1500	48	43 lbs.	21-1/8	1/2 male
160	1-1/8 x 6 · 1-1/4 x 6	2-1/4	4-1/8	1680	60-65	68 lbs.	25-3/4	1/2 male
180	1-1/8 x 6 · 1-1/4 x 6	2-5/8	6-1/8	1350	75-80	93 lbs.	29	3/4 male
140A*	1 x 4-1/4	1-7/8	4-1/4	1500	48	46 lbs.	24	1/2 male
160A*	1-1/8 x 6 · 1-1/4 x 6	2-1/4	4-1/8	1680	60-65	70 lbs.	28-3/4	1/2 male
180A*	1-1/8 x 6 · 1-1/4 x 6	2-5/8	6-1/8	1350	75-80	90 lbs.	31	3/4 male

ROCK DRILL

155	7/8 x 3-1/4 or 4-1/4 · 1 x 4-1/4	2-5/8	3	2100	110-120	61	22-3/8	3/4 male
-----	----------------------------------	-------	---	------	---------	----	--------	----------

TO ORDER CALL: 800-966-3530 OR FAX: 215-357-9193