

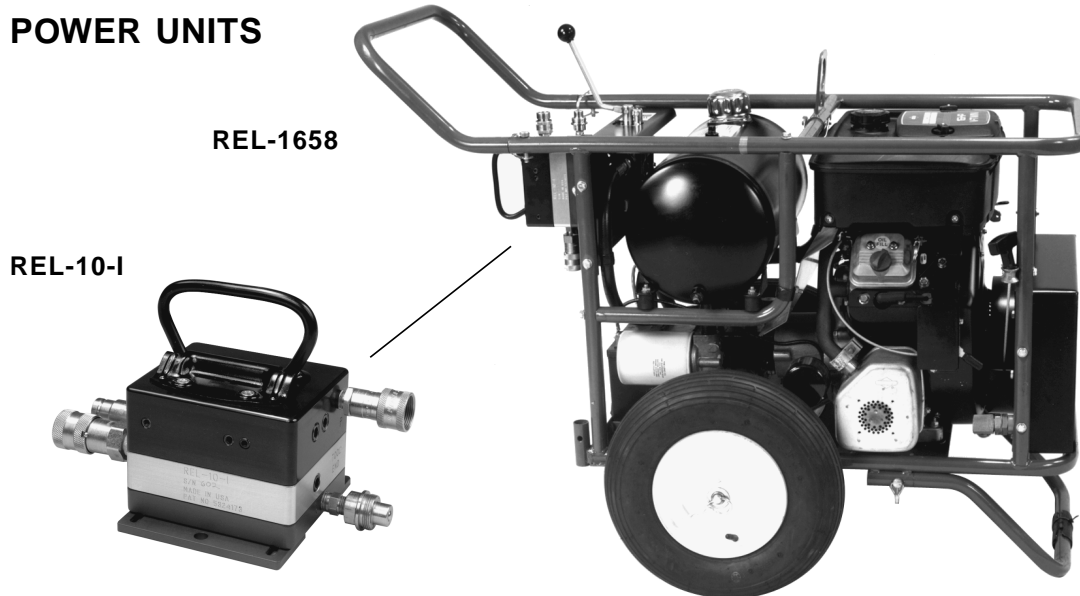

## POWER UNITS



### REL-1658 - HYDRAULIC POWER UNIT

The perfect power source for low pressure hydraulic tools. Maximum performance at any power level requirement on all kinds of jobs and in all working conditions.

#### FEATURES:

- ✓ **Low noise level for greater comfort**
- ✓ **Extremely accessible for maintenance and parts replacement**
- ✓ **Cart mounted with large 16" pneumatic tires**
- ✓ **Strong tubular frame protects the unit on the job and during transport**
- ✓ **Detachable handles and Lifting Hook for convenient storage and transport**
- ✓ **Electric Start - All controls are easily accessible for comfort and safety**
- ✓ **Large 5 Gallon Oil Reservoir**

**OPTIONAL** - By adding the REL-10-I Intensifier, you may run high pressure tools requiring 4,000-10,000 psi. (As shown in photo)

**SPECIFICATIONS:** 16 hp Briggs & Stratton Vanguard engine with electric start, System: Open Center; Rated Flow: 5/8 gpm; Relief Pressure: 2,000 psi; Weight: 265 lbs.; Fuel Capacity: 7.2 qt.; Fuel Consumption: 9 gph.

### REL-10-I INTENSIFIER (REL-4-I, 4,000 & REL-6-I, 6,000 psi Units Available)

Increase line pressure to a maximum of 10,000 psi. Compatible with all H/P hydraulic equipment. Reliable's Intensifier with only 12 moving parts will provide consistent, smooth operation and simplicity of service.

#### FEATURES:

- ✓ **High Pressure Quick Disconnects**
- ✓ **Folding handle with 90° Stop (Detachable)**
- ✓ **Adjustable mounting brackets**

**SPECIFICATIONS:** System: Open-Center, Gear Driven; Oper. Pressure: 800-2,200 psi; Flow Range: 3-8 gpm; Output: Fast Advance 305 in. 3/min.; Output: H/P 30 in. 3/min.; Relief Valve Setting: 4,000 -10,000 psi; H/P Port: 1/4" NPT; Inlet Port: 3/8" NPT; Return Port: 3/8" NPT; Weight: 9.75 lb.; Length: 5.25"; Width 4.25"; Height: 4.50".

**TO ORDER CALL: 800-966-3530 OR FAX: 215-357-9193**



*Tooling solutions for the power utility industry.*

New from Reliable this Portable Dual-Power Unit features all the options you need to run your low and high pressure hydraulic tools, even where truck access is not available.

**This compact unit will save time and money with every use.**

The Lightweight, compact design makes this unit a perfect companion for limited access areas.

## RELIABLE PORTABLE DUAL-POWER UNIT High & Low Pressure Hydraulic Power Supply



### FEATURES

- Pressure ON Valve**
- High/Low Pressure Selector**
- Reliable REL-10-I Intensifier**
- Hydraulic Fluid Reservoir**
- Visual Fluid Level Indicator**
- 8 Inch All-Terrain Wheels**
- Wheel Storage (Skid Mount)**
- H/D Tubular Steel Frame**
- Honda 6.4 hp Engine**
- High Efficiency Oil Cooler**
- Extendable Carry Handle**
- Fuel Tank**
- Lifting Eye**

**An optional low pressure unit is also available.** Consult your Reliable agent for information.

### SPECIFICATIONS

<b>Height:</b>	19.75 inches
<b>Length:</b>	36.50 inches
<b>Width:</b>	21.25 inches
<b>Weight:</b>	85 pounds (dry)

A single pump provides the power needed for high or low pressure tool operation.

The twin pressure design features 1,400 PSI output on the low pressure side, and the REL-10-I intensifier supplies 10,000 PSI for all of your high pressure applications.

A combination of the finest materials and features provide continuous and dependable service under the rigorous demands of the power utility and line construction industry.

**Reliable performance from the HONDA, 6.4 HP, gasoline engine.**

The high efficiency hydraulic fluid cooler, 1.5 gallon hydraulic fluid reservoir, and Open Center system enhance performance and may reduce service cost and extend tool life.

**All in one convenient package.**

We have mounted all of these and many more features on a heavy duty tubular frame with 8 inch all terrain wheels.

### DIMENSIONS

<b>System Type:</b>	Open Center
<b>Flow Rate:</b>	6 GPM @ 1,400 PSI
<b>Reservoir:</b>	1.5 Gallons
<b>Low Pressure:</b>	1,400 PSI max.
<b>High Pressure:</b>	10,000 PSI max.

**This unit is ready to go, ANYWHERE!**

**TO ORDER CALL: 800-966-3530 OR FAX: 215-357-9193**



*Tooling solutions for the power utility industry.*

## HG3555A - PORTABLE POWER UNIT - DUAL CIRCUIT

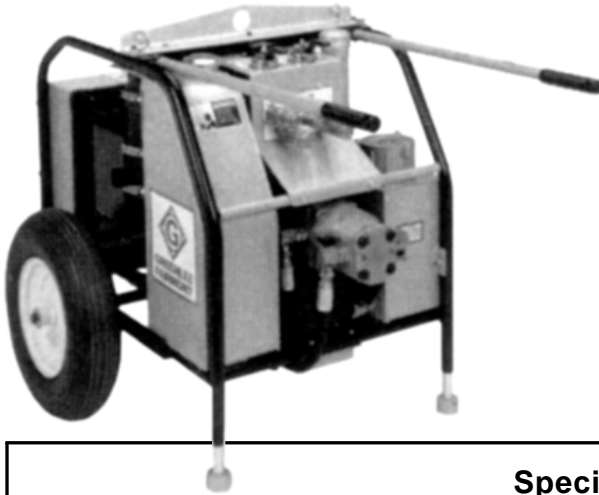

Can be taken quickly to any job site.  
 Gasoline Powered.  
 Open-Center System.  
 Electric Start.  
 Tubular frame protects components, providing easy handling.  
 Oil Cooler standard.  
 16 in. pneumatic wheels.  
 On/Off selector valve.  
 HTMA type coupler included.

<b>Weight</b> 314 lbs. dry	<b>Specifications:</b>
	<b>Type:</b> Dual circuit, compact, portable
<b>Length</b> 33.5"	<b>Capacities:</b> Gasoline - 4 gal. Hydraulic Oil - 2.8 gal.
	<b>Rated Flow:</b> 2 - 5 gpm circuits or combined 1-10 gpm circuit
<b>Width</b> 32.5"	<b>Relief Pressure:</b> 2,000 psi
	<b>Filtration:</b> 10 Micron, replaceable
<b>Height</b> 30"	<b>Oil Cooler:</b> Standard engine driven fan
	<b>Engine:</b> 20 hp Kohler Magnum
	<b>Pressure Port Thread:</b> 1/2 in. NPTF
	<b>Return Port Thread:</b> 1/2 in. NPTF

### 49113 - Portable Power Unit

Same as above, Battery Not Included. (for shipment outside North America)

## ACCESSORIES FOR POWER UNITS

Part	Description	For Use With	HG3503A	49114	HG3558B	49113
135586	Wheel and handle		x	x		
138448	Automatic Throttle Control		x	x		
158151	16 in. Wheel Kit				x	x
158152	Lifting Eye				x	x



**IF YOU DON'T SEE WHAT YOU NEED  
 CONTACT RELIABLE EQUIPMENT  
 800-966-3530**

**TO ORDER CALL: 800-966-3530 OR FAX: 215-357-9193**